

Sistema modular 25 bar

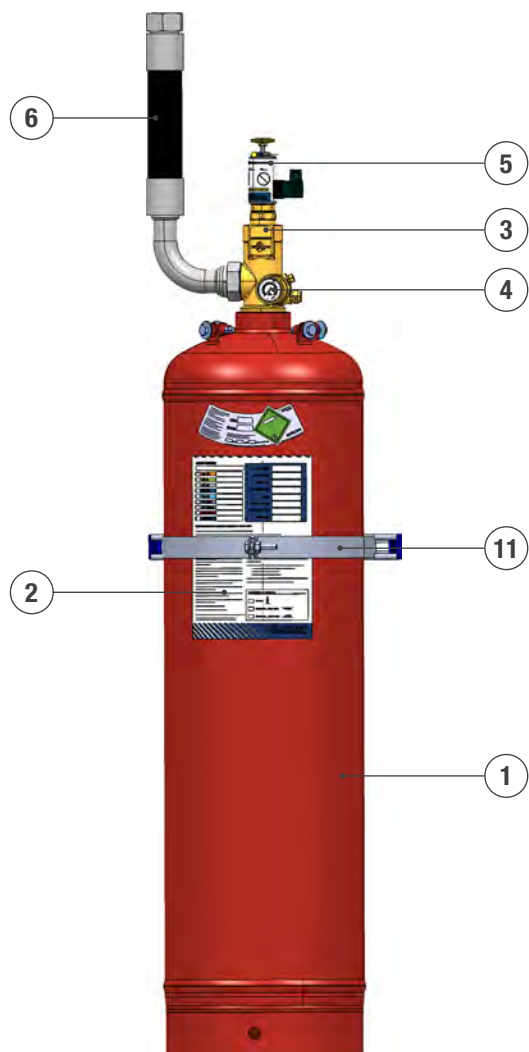

Item	Descrição
1	Cilindro
2	Etiqueta do agente extintor
3	Válvula de descarga do cilindro
4	Manómetro com pressóstato
5	Atuador solenóide + disparo manual
6	Mangueira de descarga
7	Adaptador de tubagem (OGS) Ranhurado DN33 Ø48,3 // DN50 Ø60,3
8	Joelho 3000 lbs e porca de tubo (OGS)
9	Adaptador de tubagem (A) Ranhurado DN33 11/2" NPT // DN50 2" NPT
10	Joelho 3000 lbs (A)
11	Suporte

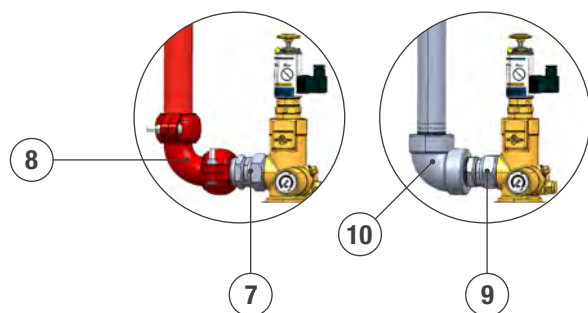
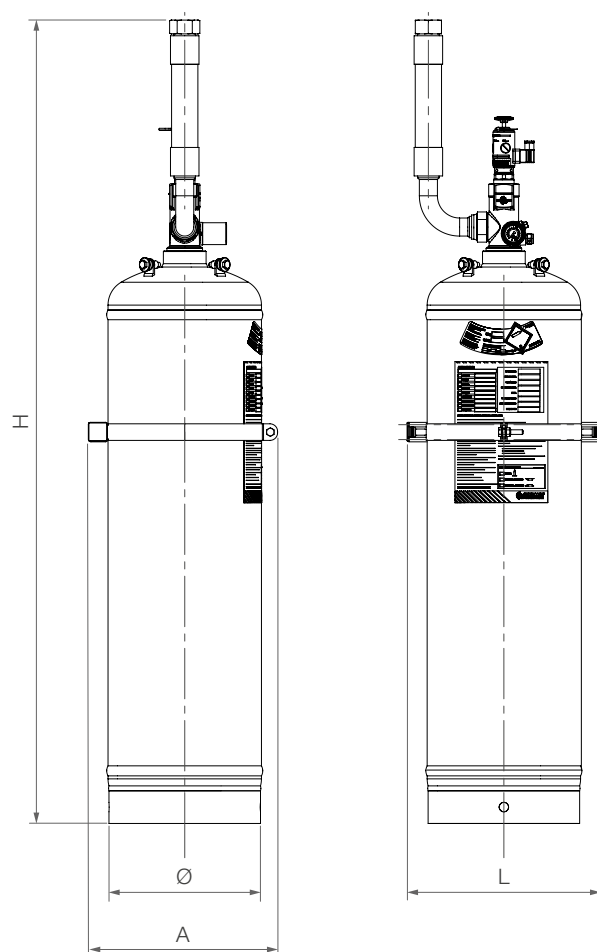

Referência	Válvula	Volume (L)	Ø (mm)	H (mm)	A (mm)	L (mm)
STC-FK5-40-LP-33	DN33	40	323	1151	398	408
STC-FK5-51-LP-33	DN33	51	323	1296	398	408
STC-FK5-67-LP-33	DN33	67	323	1606	398	408
STC-FK5-81-LP-33	DN33	81	323	1691	398	408
STC-FK5-81(406)-LP-33	DN33	81	406	1318	482	508
STC-FK5-100-LP-33	DN33	100	406	1473	482	508
STC-FK5-120-LP-33	DN33	120	406	1638	482	508
STC-FK5-142-LP-50	DN50	142	406	1894	482	508
STC-FK5-150-LP-50	DN50	150	406	1959	482	508
STC-FK5-180-LP-50	DN50	180	600	1520	676	708
STC-FK5-243-LP-50	DN50	243	600	1755	676	708

